

Märklin Electronic train controller 6600

H I B O

1. Starting acceleration control
2. Braking retardation control
3. Length-of-stop control
4. on/off, starting acceleration, braking retardation and load distribution
5. on/off, pause/commuter operation
6. Emergency stop
7. Speed control

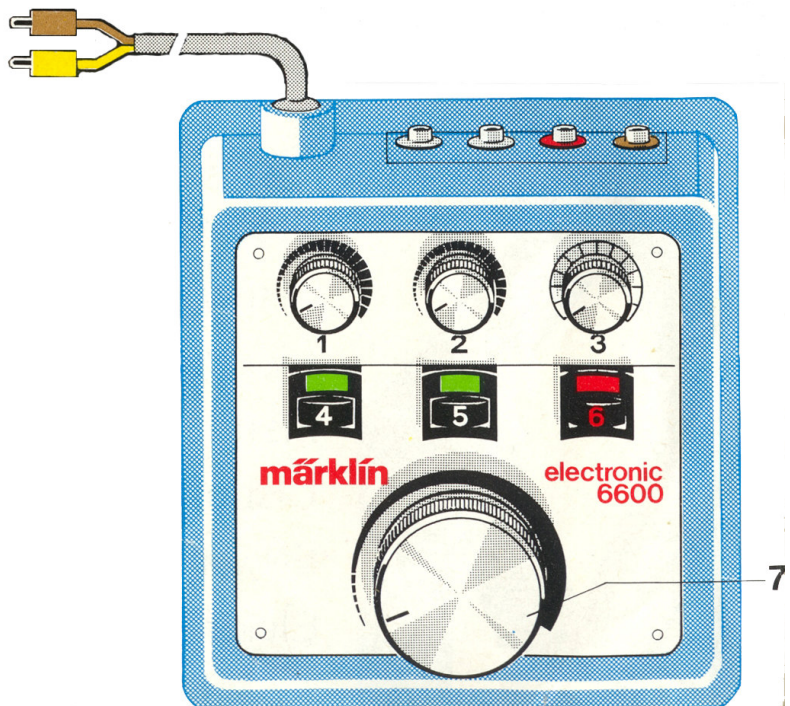

Connection to traction transformer

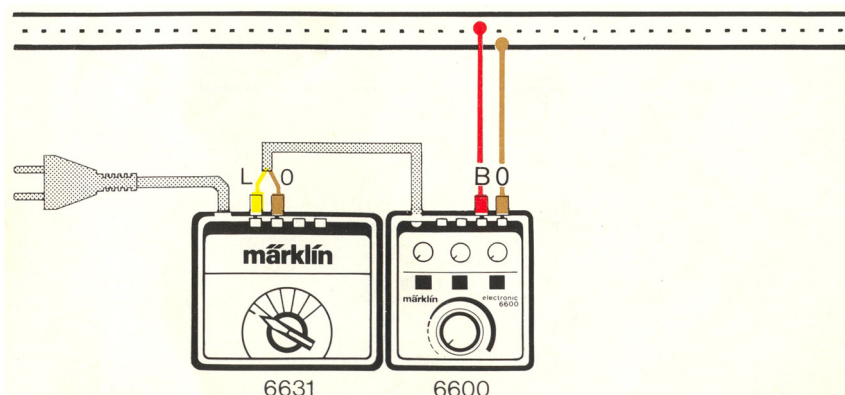

Connection to lighting transformer

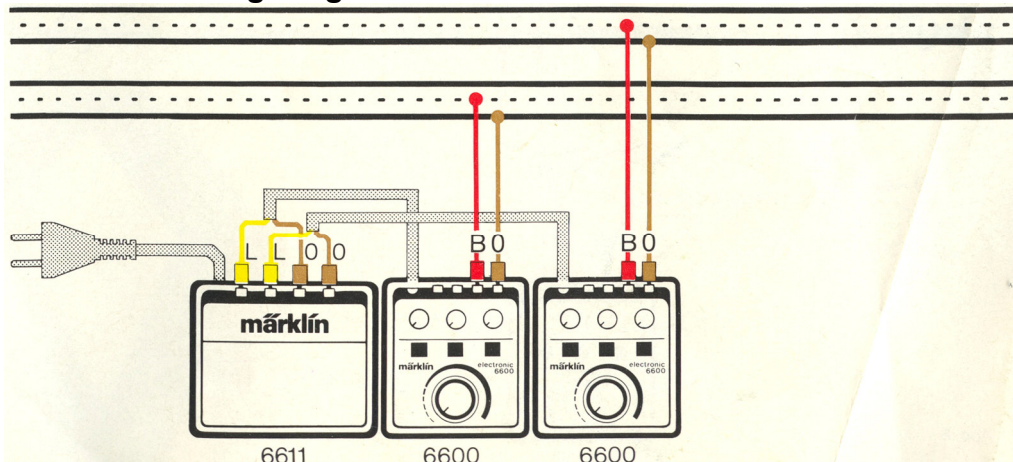

Speed control – range of adjustment

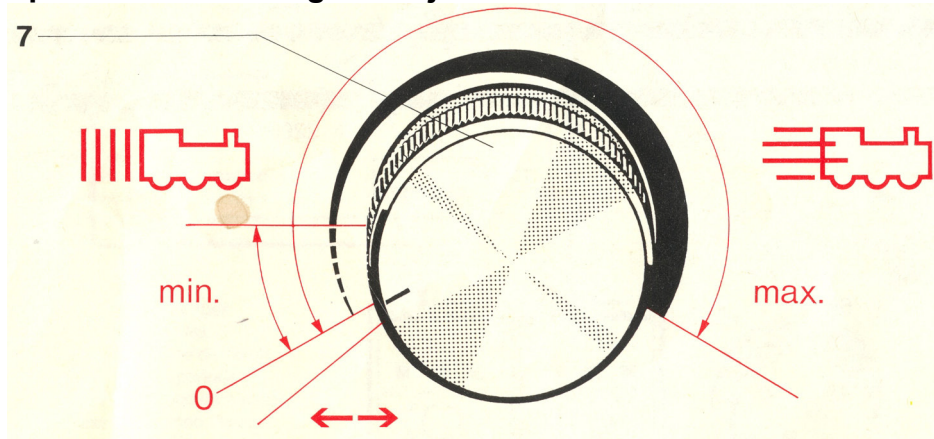

Controls 1 - 3

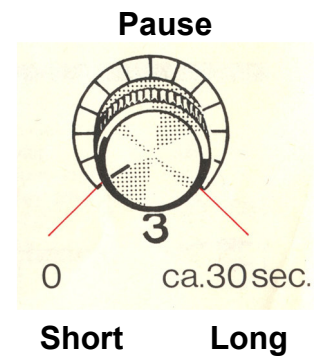
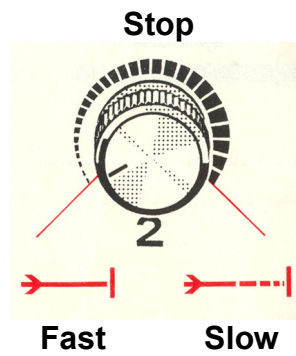
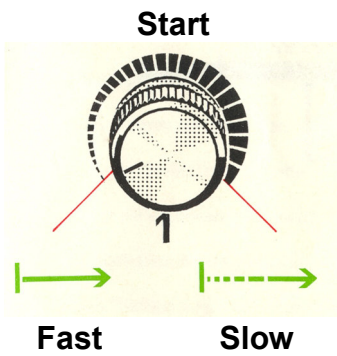

Automatic pause

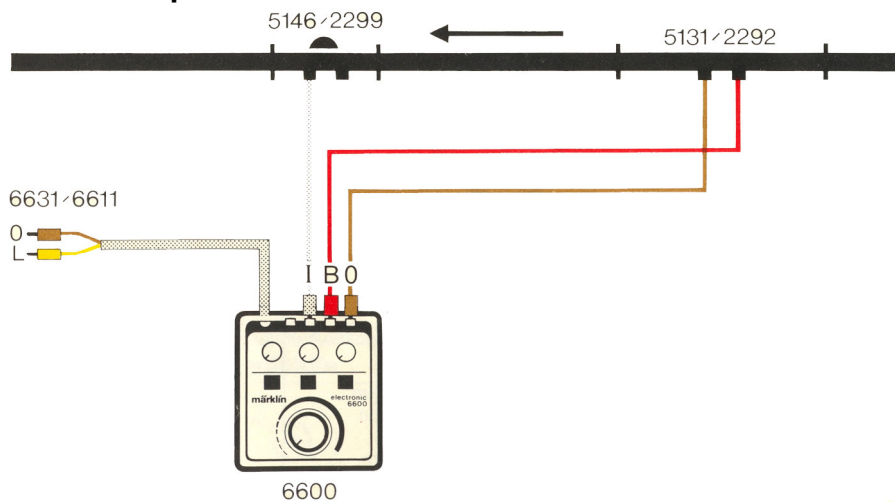

Pause controlled by second train

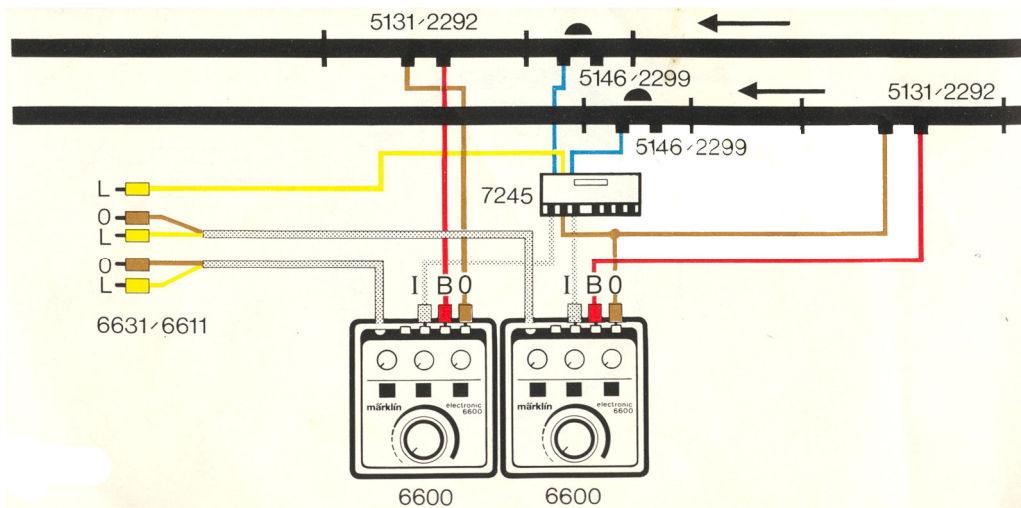

Automatic commuter operation

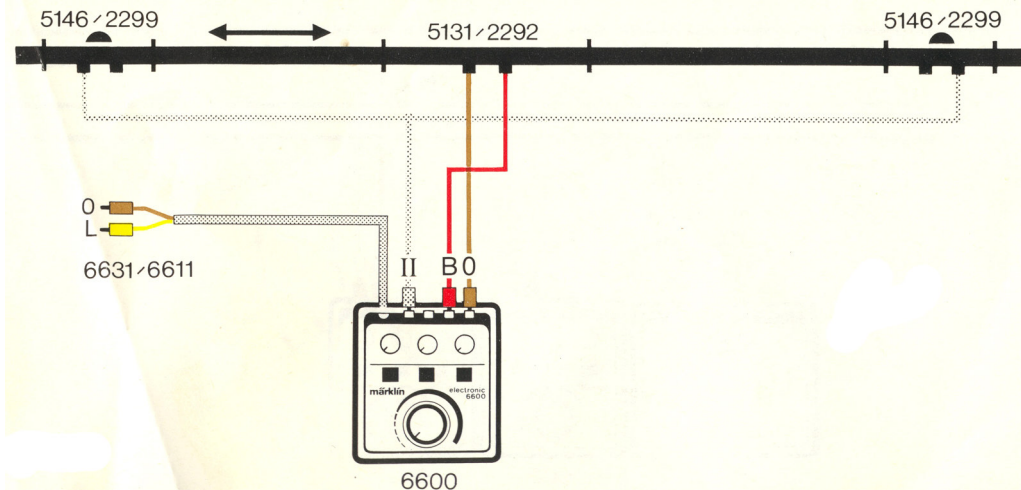

Braking before change of direction

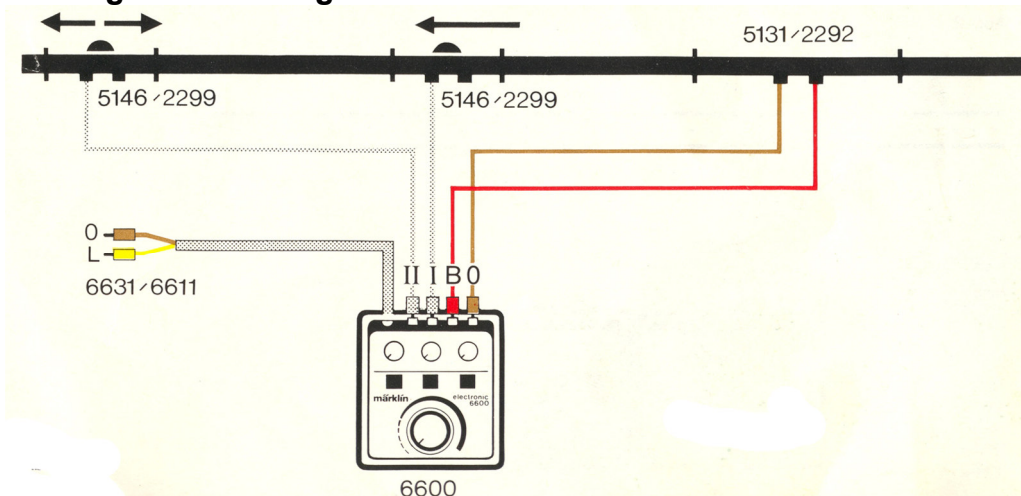

Automatic pushing-off with TELEX

